

Hemoglobin Reference Failure Troubleshooting

The HEMOGLOBIN REFERENCE FAILURE error (“HGB REF FAILURE”) is generated by the Vet ABC as a quality control check for hemoglobin measurement. Recall that the analyzer measures hemoglobin by first lysing the red blood cells in the sample, then converting the hemoglobin that is released into a light-absorbing compound. The amount of light absorbed by this compound is proportional to the quantity of hemoglobin that is present. To ensure that this measurement is performed accurately, the Vet ABC-Diff first determines the amount of light absorbed by the reagents alone, before any blood is added, and this absorbance is factored out of the patient determination. This is referred to as “blinking” the reagents. The instrument determines this “blank” value before each patient sample and compares the reading to the previous blank as a quality control check. If the current and previous readings are significantly different, the instrument places an exclamation point beside the HGB result. The ABC also determines the blank value as part of the Startup cycle, and if this blank is significantly different from the previous run, the “HGB REFERENCE FAILURE” message appears.

In summary, then, two conditions must exist for the hemoglobin blanking procedure to proceed correctly. Reagent must be present in the measuring chamber, and the photometer (i.e. the light detecting mechanism) must be functioning properly.

Troubleshooting a Hgb Reference Failure, therefore, should be as follows:

- 1) Open the door of the ABC run a Startup cycle, watching the mixing and RBC chambers as the cycle progresses. Do the chambers fill with fluid at any point in the cycle? If not, this is probably the cause of the failure. Determine the cause as follows:
 - A) Was this pack recently installed? If so, were the red plugs removed prior to inserting the pack?
 - B) The pack may not be not seated well - burp the pack, remove, and reseal
 - C) If the red plugs were still attached, or the pack wasn't seated well, the instrument may have drawn a sizeable quantity of air into the system while attempting to pass Startup. Run several Prime cycles (SERVICE – REAGENT PACK – PRIME) and watch for fluid to appear in the chambers. If reagent appears, run a

- Startup cycle. If the failure still occurs, 2 – 3 more Primes may be needed to remove air bubbles from the chamber.
- D) If fluid still does not appear, remove the pack and hold the bottom end over a sink. Insert a pen or hemostat into each of the three ports and watch for reagent to flow out. If no reagent is present, the pack has been used up or the pack is defective. Determine which is the cause – we will replace a defective pack free of charge.
 - E) Install a new pack using the Change Pack program, then run a Startup cycle, watching for reagent to enter the chambers.
- 2) If reagent is entering the chambers, and the HGB Reference Failure is still occurring, the photometer may need to be adjusted. The following procedure explains how to make this adjustment. Note that reagent **must be present** in the WBC/HGB chamber before making this adjustment. Do not attempt to adjust the photometer without ensuring the reagent is flowing properly!

IMPORTANT NOTES

If the analyzer has been turned off, switch it on and allow it to warm up for at least 30 minutes before adjusting the photometer. Also, perform a concentrated cleaning to remove any debris that may have accumulated on the photometer (Note that this does not apply to new instrument installations).

You will also need the following tools:

1. Silver key to open front cover (in accessories kit)
2. Orange handled screwdriver (in accessories kit)
3. Very small flat-head screwdriver (size 1.4 to 2.9 mm)

ADJUSTMENT PROCEDURE

1. To reach the photometer adjustment screw, you will need to take the top cover off the analyzer. Place the silver key in the black rubber door latch on the left side of the instrument and turn until the door opens.
2. Unscrew the 5 cover fixation screws. There is one below the rubber door latch, two on the back of the instrument at the far right top and bottom, and two at the top of the reagent compartment (see diagrams on next page). Do not completely unscrew the two above the reagent compartment. They are easily dropped into the interior of the analyzer. Remove the three screws on the back of the analyzer, then loosen the final two just enough to remove the cover panel.

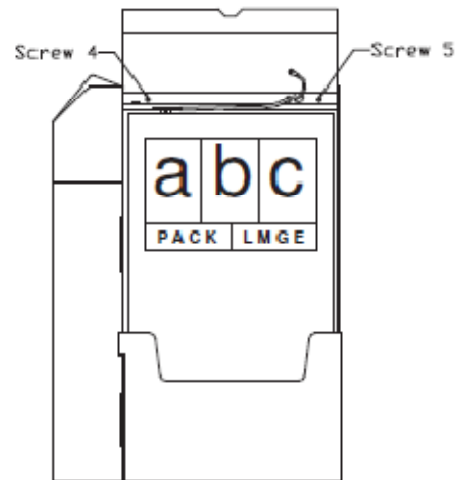
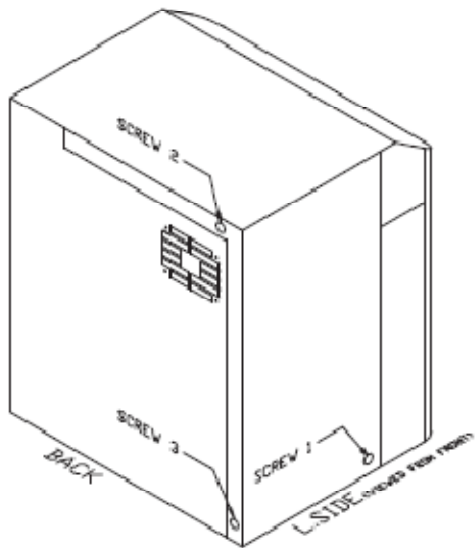

3. Lift off the instrument cover. Look into the interior of the instrument and locate the green circuit board attached to the back of the analyzer.
4. Refer to the circuit board diagram on the next page and locate adjustment block #R97 in the top right hand corner (circled). Then examine the circuit board in the analyzer and locate the same block. The block is a blue, horizontally-oriented rectangle with the number R97 printed on the circuit board adjacent to the block. Note the small screw in the lower right corner of the block. When instructed in Step #6, you will use the small flat-head screwdriver to turn this screw.

CIRCUIT BOARD DIAGRAM

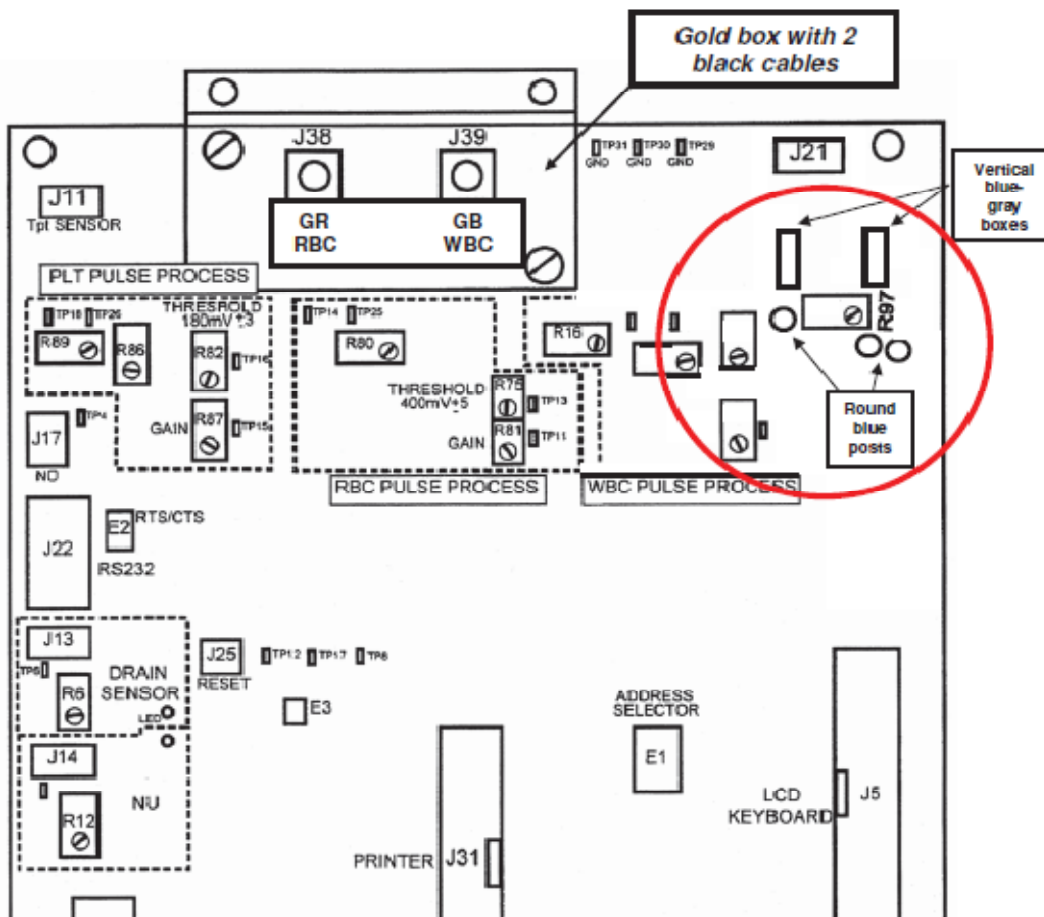

5. Now go into the analyzer's Technician menu to adjust the photometer to the proper setting. From the Main Menu, perform the following steps:
 - a. Cursor to **4) SERVICE** and press ENTER
 - b. Cursor to **8) TECHNICIAN** and press ENTER
 - c. At the **PASSWORD** prompt, type in the numbers **421** and press ENTER
 - d. Cursor to **2) ADJUSTMENTS** and press ENTER
 - e. Cursor to **1) CAL PHOTOMETER** and press ENTER

NOTE: DO NOT CHANGE ANY OTHER SETTINGS IN THE TECHNICIAN MENU!!! This menu contains adjustments that, if altered, will dramatically affect the performance of your analyzer. If there are any questions or concerns about performing this procedure correctly, please phone 1-866-382-6937.

6. In about 30 seconds, a number will appear on the screen. This is the current setting for the hemoglobin photometer and, when properly adjusted, is usually around 237. While the number is displayed on the screen, turn the screw on the R97 block until the number 237 or 238 is displayed. Turn the screw clockwise to increase the number and counterclockwise to decrease the number. Several revolutions of the screw may be necessary. If the number disappears before the adjustment is completed, perform steps 5 and 6 again until the photometer is set correctly.
7. Now run a STARTUP cycle by pressing the yellow STARTUP button on the face of the analyzer. If STARTUP fails or the HEMOGLOBIN REFERENCE FAILURE error appears, run the STARTUP cycle a second time. If the error still occurs, phone Vet Novations Technical Support for assistance (1-866-382-6937).
8. If STARTUP passes, replace the analyzer cover. Run the level of control that you are currently using and verify that the analyzer is recovering all values correctly. If the control is within specified limits, the instrument is ready to run patient samples.